

U.S. Department of Justice

Civil Rights Division

Disability Rights Section

ADA Checklist for New Lodging Facilities

[Introduction and Instructions](#) • [Survey Tools and Techniques](#) • [ADA Checklist for New Lodging Facilities](#)

Introduction

Hotels, motels, inns and other places of lodging must comply with the Americans with Disabilities Act (ADA). This publication is a self-help survey that owners, franchisors, and managers of lodging facilities can use to identify ADA mistakes at their facilities. Using this survey will not identify all possible ADA problems -- it will simply identify some of the most common ones. However, by using this survey, owners, managers, and franchisors can identify and fix most ADA mistakes at their facilities.

This survey asks questions in a simple "yes/no" format, using plain nontechnical language. If the person surveying a lodging facility can accurately answer "yes" or "not applicable" to all questions on this survey, then the lodging facility surveyed is free of most ADA problems. ADA mistakes are identified on this survey each time a question is accurately answered "no."

ADA Requirements

Under the ADA, hotels, motels, inns and other places of lodging designed or constructed after January 26, 1993, must be usable by persons with disabilities. To meet this requirement, lodging facilities must comply with certain regulations published by the Justice Department. The regulations contain detailed architectural requirements called the ADA Standards for Accessible Design (Standards), 28 C.F.R. pt. 36, Appendix A. Each question in the survey describes a requirement contained in the regulations

The Standards are designed to ensure accessibility for individuals with a wide variety of different

disabilities, such as persons who are blind or have low vision, people who are deaf or hard of hearing, persons with limited use of hands or arms, individuals with mobility impairments who use canes, crutches, braces or walkers, persons who use wheelchairs, and people who have combinations of disabilities. Thus, the Standards include architectural requirements that address the different needs of persons with each of these types of disabilities. For example, the Standards include requirements for braille and raised letter signs and cane-detectable warnings of safety hazards for persons who are blind or have low vision. The Standards require lodging facilities to install visual fire alarms and to have rooms that are equipped for persons who are deaf or hard of hearing. The Standards require door hardware, heating and air conditioning controls, and faucet controls that do not require tight pinching, twisting, or grasping for persons with limited use of hands or arms. For persons who use mobility aids because they cannot walk or have problems walking or climbing stairs, the Standards require there to be ways of traveling throughout the facility that do not steps, stairs, or other abrupt level changes. And, the Standards require doors with 32 inches of clear passage width, ramps and curb cuts for persons who use wheelchairs, crutches, and other mobility aids.

Lodging facilities must comply with all of the requirements in the Standards that are applicable. And, because a difference of inches or, in some cases, a difference of a fraction of an inch can pose a serious safety hazard or result in the denial of access for persons with disabilities, full compliance with the Standards is essential.

This publication was designed to help owners, franchisors, managers, and operators of newly constructed lodging facilities understand the ADA requirements that apply to their facilities. This publication is not intended to be an exhaustive list of all of the ADA problems that can occur at a lodging facility. However, it is a list of common problems that the Justice Department has identified during on-site investigations and compliance reviews of lodging facilities.

In addition to increasing understanding of the ADA requirements that apply to lodging facilities, this survey can also be used by lodging facility owners, franchisors, managers, or operators to obtain written confirmation that a lodging facility complies with the ADA requirements from an architect and/or a building contractor.

Instructions

The publication consists of three parts: **(1) the [Introduction and Instructions](#); (2) [Survey Tools and Techniques](#); (3) the [ADA Checklist for New Lodging Facilities](#).** The Introduction and Instructions explain the purpose and uses of this form and explain how to complete the Checklist. Survey Tools and Techniques explains how to make certain measurements required to complete the Checklist. The Checklist contains common ADA problems identified during surveys of lodging facilities and will help you to determine if these problems exist at your lodging facility.

To use this survey most effectively, you should:

- **Be familiar with the [ADA Regulations](#) including the ADA Standards.** For a free copy of the regulations, call the ADA Information Line at 1-800-514-0301 (voice) 1-800-514-0383 (TTY). Other helpful [ADA publications](#) relating to lodging facilities are also available free of charge.

- **Inspect the facility.** You cannot complete the Checklist without conducting an on-site inspection of the facility to make visual observations and take specific measurements. The Survey Tools and Techniques section of this publication explains how to make certain measurements required to determine if a facility meets ADA requirements.
- **Complete the ADA Checklist for New Lodging Facilities.** The Checklist describes some of the most common accessibility problems at lodging facilities. If you cannot answer "Yes" or "Not Applicable" ("N/A") to all of the questions on the Checklist, then your lodging facility does not comply with the ADA requirements, and all problems must be fixed.

Questions concerning this publication, requests for free copies of this publication or copies of the ADA Standards, and general or technical questions about ADA requirements should be directed to:

The [ADA Information Line](#) (800) 514-0301 voice ■ (800) 514-0383 TTY

ADA information is also available on the Justice Department's ADA Home Page on the Internet at <http://www.usdoj.gov/crt/ada/index.html>.

ADA Checklist for New Lodging Facilities

I. Parking and Loading Zone...

A. If "self parking" is provided, are at least the minimum number of accessible parking spaces provided as required by the table below in surface lots or parking garages, including "van accessible" spaces for those who use lift-equipped vans? [ADA Standards 4.1.2(5)]

(Note: Following each question in this document is a reference to the ADA Standards for Accessible Design, 28 C.F.R. pt. 36, Appendix A. This reference identifies the section of the Standards that sets out the requirements described in the question.)

Yes No N/A Comments: _____

Total Spaces in Lot	Acc. Spaces Required
1-25	1 van
26-50	1 std. + 1 van
51 - 75	2 std. + 1 van
76-100	3 std. + 1 van
101-150	4 std. + 1 van
151-200	5 std. + 1 van

201-300	6 std. + 1 van
301-400	7 std. + 1 van
401-500	7 std. + 2 van
501-1000	2% of total spaces*
1001 and over	20 + (1 per 100 over 1000)*
Standard Accessible (std.) parking space is 8 foot min.. + 5 foot access aisle	
* One in every 8 accessible parking spaces must be a van accessible space with an 8 foot wide access aisle.	

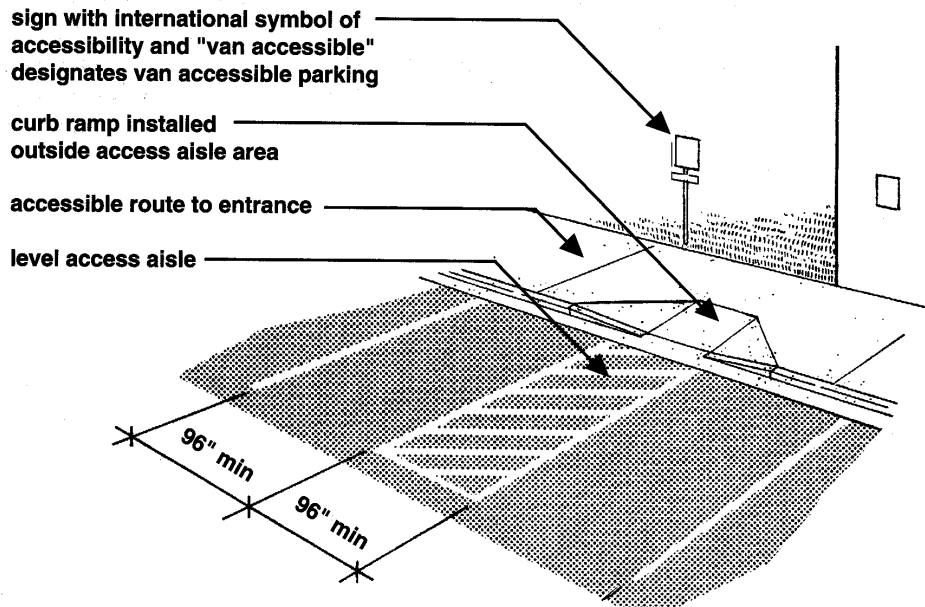

Diagram of Van Accessible Parking Space Elements

D

B. Does each accessible parking space have or share an adjacent access aisle to allow persons who use wheelchairs, walkers or other mobility aids to transfer from their car/van? [ADA Stds. 4.6.3]

Yes ___ No ___ N/A ___ Comments:

C. Do the parking spaces and access aisles have surface slopes less than 1:50 (i.e.: when measured as shown on the Tools & Techniques page , is the critical dimension 1/2" or less)? [ADA Stds. 4.6.3]

Yes ___ No ___ N/A ___ Comments:

D. Does each accessible parking space have a post- or wall-mounted sign with the symbol of accessibility mounted high enough so the sign is visible when a vehicle is parked in the

space? [ADA Stds. 4.6.4]

Yes ___ No ___ N/A ___ Comments:

E. Are the level surfaces of accessible parking spaces and access aisles free of "built-up" curb ramps so persons who use mobility aids (e.g.: wheelchairs, walkers or crutches) can make convenient transfers? [ADA Stds. 4.6.3]

Yes ___ No ___ N/A ___ Comments:

F. If there is more than one accessible parking space, are the accessible parking spaces the closest parking spaces to the lobby entrance and accessible guestroom entrance(s)? [ADA Stds. 4.6.2]

Yes ___ No ___ N/A ___ Comments:

G. If the lodging facility has covered passenger pickup/drop-off areas, does the pavement at such area(s), including the required 5' wide access aisle, slope 1:50 or less (critical dimension of ' or less)? [ADA Stds. 4.6.6]

Yes ___ No ___ N/A ___ Comments:

H. Is the height of the covered passenger pickup/drop-off area at least 9'-6" to allow vans with raised roofs to use such area? [ADA Stds. 4.6.5]

Yes ___ No ___ N/A ___ Comments:

I. Does the parking garage serving the lodging facility allow at least 98" of vertical clearance for vehicles with raised roofs to approach, use and exit the accessible parking spaces? [ADA Stds. 4.6.5]

Yes ___ No ___ N/A ___ Comments:

II. Exterior Routes...

In order for persons with disabilities to use a facility, there must be at least one accessible route that allows persons who use wheelchairs or other mobility aids to approach, enter and use each facility on a given site. Those routes cannot have, among other things, steep slopes or cross slopes, abrupt level changes or steps. In addition, for persons who are blind or have low vision, none of the pedestrian walkways at a facility may have objects that project too far into the paths. Following are questions to

determine whether your facility meets some key requirements of the ADA accessible route requirements.

A. Regarding the exterior routes (e.g.: sidewalks and walkways), are there no steps, no abrupt level changes over 1/4", and no unramped curbs that will impede access for persons who use wheelchairs, walkers and other mobility aids between...

1. ...the accessible parking space access aisles (both guest and employee parking areas) and an accessible entrance door to each building? [ADA Stds. 4.1.2(1)]

Yes ___ No ___ N/A ___ Comments:

2. ...the accessible parking space access aisles and the exterior doors to the accessible guestroom(s)? [ADA Stds. 4.1.2(1)]

Yes ___ No ___ N/A ___ Comments:

3. ...the accessible passenger pick-up/drop off area and an accessible entrance door? [ADA Stds. 4.1.2(1)]

Yes ___ No ___ N/A ___ Comments:

4. ...the lobby and the accessible guestrooms with exterior room doors? [ADA Stds. 4.1.3(1)]

Yes ___ No ___ N/A ___ Comments:

5. ...the accessible guestroom(s) and exterior amenities, such as swimming pools, whirlpools, dressing areas, restrooms, picnic areas, bars and outdoor dining areas? [ADA Stds. 4.1.2(2)]

Yes ___ No ___ N/A ___ Comments:

6. ...the public sidewalk (if provided) or street, and an accessible entrance door to the lobby? [ADA Stds. 4.1.2(1)]

Yes ___ No ___ N/A ___ Comments:

7. ...an accessible entrance to the facility and the public transportation stops serving this site? [ADA Stds. 4.1.2(1)]

Yes ___ No ___ N/A ___ Comments:

8. ...ground level fire exit doors (including any at loading docks) and a driveway, public sidewalk, street or other "public way"? [ADA Stds. 4.1.3(9)]

Yes ___ No ___ N/A ___ Comments:

B. Examine each of the exterior routes described above, to confirm the following:

1. ...do the sidewalks have cross slopes (i.e.: slopes tilting side to side) less than 1:50 (critical dimension of 4' or less) so persons who use wheelchairs can conveniently negotiate the routes? [ADA Stds. 4.3.7]

Yes ___ No ___ N/A ___ Comments:

2. ...excluding ramps described below, do the sidewalks have running slopes (i.e.: in the direction of travel) that are no greater than 1:20 (1 1/4" critical dimension or less)? [ADA Stds. 4.3.7]

Yes ___ No ___ N/A ___ Comments:

3. ...is the usable width of sidewalks at least 36" wide to accommodate wheelchair travel, even if cars project over the curb onto the sidewalk? [ADA Stds. 4.3.3]

Yes ___ No ___ N/A ___ Comments:

4. ...are the curb ramps at least 36" wide, excluding the flared sides, to allow for convenient wheelchair travel? [ADA Stds. 4.7.3]

Yes ___ No ___ N/A ___ Comments:

5. ...do the curb ramps have running slopes of 1:12 or less (critical dimension of 2" or less)? [ADA Stds. 4.7.2]

Yes ___ No ___ N/A ___ Comments:

6. ...are the other exterior ramps at least 36" wide (between handrails)? [ADA Stds. 4.8.3]

Yes ___ No ___ N/A ___ Comments:

7. ...do the exterior ramps have running slopes of 1:12 or less (critical dimension of 2" or less)? [ADA Stds. 4.8.2]

Yes ___ No ___ N/A ___ Comments:

8. ...do the gratings on the sidewalks and walkways have spaces no more than 1/2" wide in the direction of travel so that canes, crutches and walkers do not slip into them, causing an individual to fall? [ADA Stds. 4.5.4]

Yes ___ No ___ N/A ___ Comments: _____

9. ...do the exterior ramps have the following features:

a. top and bottom landings that are level, at least as wide as the ramp they serve, and at least 60" long to allow for adequate maneuvering and resting space for persons who use wheelchairs, walkers, and other mobility aids? [ADA Stds. 4.8.4]

Yes ___ No ___ N/A ___ Comments: _____

b. if a ramp is more than 30' long, is there a middle landing that is level, at least as wide as the ramp run it serves and at least 60" long? [ADA Stds. 4.8.4]

Yes ___ No ___ N/A ___ Comments: _____

c. are the exterior ramps at least 36" wide between the two handrails to allow for convenient wheelchair travel? [ADA Stds. 4.8.3]

Yes ___ No ___ N/A ___ Comments: _____

d. do the exterior ramps have running slopes that are 1:12 or less (critical dimension of 2" or less)? [ADA Stds. 4.8.2]

Yes ___ No ___ N/A ___ Comments: _____

10. ...are all exterior stairs built so blind persons and persons with low vision will not hit their head(s) on the underside (i.e.: protected with a cane detectable warning, such as the planter shown below or enclosed with walls so a continuous 80" high circulation path is provided for building users)? [ADA Stds. 4.4.2]

Yes ___ No ___ N/A ___ Comments: _____

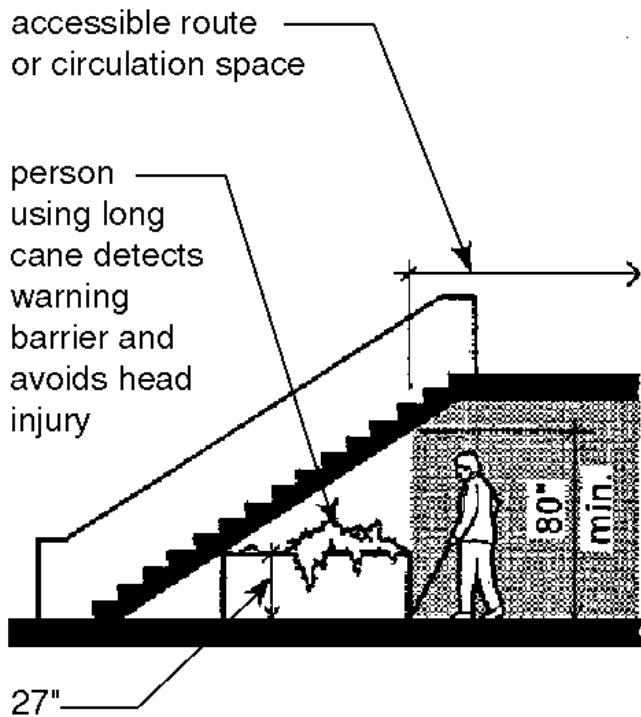

D

Sketch based on ADA Stds. Figure 8(c-1)

11. ...since blind persons and persons with low vision can walk on any sidewalks, are all sidewalks and walkways free of any objects (i.e.: fire extinguishers, wall mounted lights, electrical meters, signs, pay phones, trees, shrubs, etc.) that pose a hazard to blind persons and persons with low vision by projecting into the path more than 4"? [ADA Stds. 4.4; 4.1.2(3); 4.1.3(2)]

Yes No N/A Comments: _____

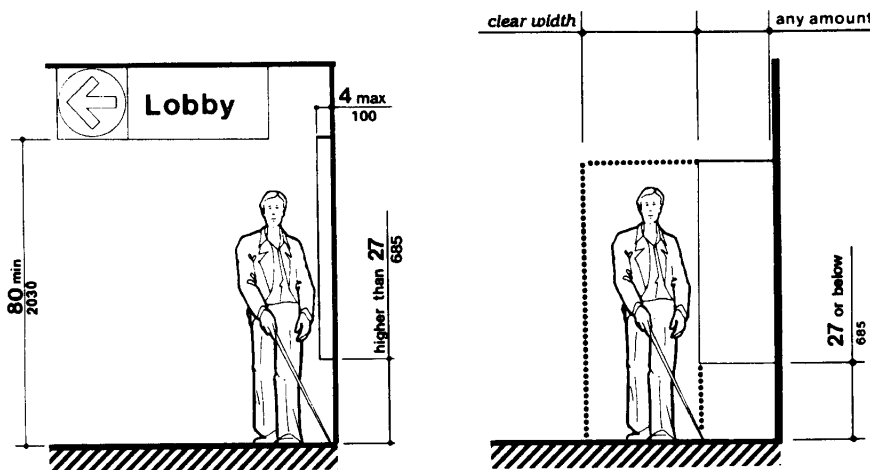

D

Overhead Hazards ADA Stds. Figure 8(a) - Walking Parallel to a Wall

III. Building Entrances & Lobby...

A. If a fully automatic door is not provided, is the walkway in front of the lobby door level, without any portion steeper than 1:50 (critical dimension of 1/4" or less), so persons who use wheelchairs do not roll away from the door when they take their hand off the wheelchair and reach for the door hardware? [ADA Stds. 4.13.6]

Yes No N/A Comments: _____

B. Does at least one lobby entrance door allow at least 32" clear passage width so persons who use wheelchairs, walkers, crutches, and other mobility aids can get through the door? [ADA Stds. 4.13.5]

Yes No N/A Comments: _____

C. Is the door hardware (lever, pull, panic bar, etc.) usable with one hand, without tight grasping, pinching or twisting of the wrist, since many persons with disabilities may not have high manual dexterity or use of both hands? [ADA Stds. 4.13.9]

Yes No N/A Comments: _____

D. If there is a vestibule without fully automatic doors, is there a 30"x48" clear floor space where one can be outside the swing of a hinged door (i.e.: for out-swinging doors, at least 7'-0" between the exterior door frame and interior door frame as shown in the sketch below) to allow persons who use wheelchairs to proceed through one door without it closing on them and binding the wheelchair as they approach and open the next door? [ADA Stds.4.13.7]

Yes No N/A Comments: _____

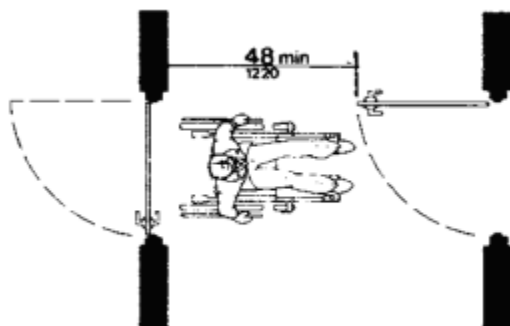

ADA Stds. Figure 26 - Two Hinged Doors in Series

E. If there is key card controlled door hardware on building entrances, is the key card reader positioned

so persons who use wheelchairs may approach and operate the opener (48" high maximum if only front approach, 54" high if parallel approach is available)? [ADA Stds. 4.1.3(13); 4.27.3; 4.2.5; 4.2.6]

Yes ___ No ___ N/A ___ Comments: _____

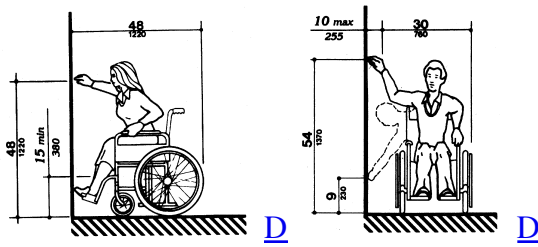

forward reach and side reach

ADA Stds. Figure 5(a) and 6(b) - Forward and Side Reach Ranges for Wheelchairs

F. Do the registration counters or other counters serving guests have a lowered portion no more than 36" high or is there a folding shelf at 36" high to allow persons who use wheelchairs to fill out registration forms? [ADA Stds. 7.2]

Yes ___ No ___ N/A ___ Comments: _____

G. If a counter is used for serving breakfast or other food products, does it have at least a 36" long section that is no higher than 36" above the floor to allow persons who use wheelchairs to reach self-serve items? [ADA Stds. 7.2]

Yes ___ No ___ N/A ___ Comments: _____

IV. Interior Routes...

A. Abrupt Level Changes - Are hallways and corridors free of any steps or abrupt vertical level changes over 1/4" that will impede access for persons who use wheelchairs, walkers, and other mobility aids between... [ADA Stds. 4.1.3(1)]

...the lobby and accessible guestrooms, suites, and other sleeping rooms?

Yes ___ No ___ N/A ___ Comments:

...the lobby and any restaurants, other dining areas, and vending/ice machine areas?

Yes ___ No ___ N/A ___ Comments:

...the lobby and any ballrooms or meeting rooms?

Yes ___ No ___ N/A ___ Comments:

...the lobby and the public and employee restrooms?

Yes ___ No ___ N/A ___ Comments:

...the lobby and gift shops, newsstands, or other retail shops in the facility?

Yes ___ No ___ N/A ___ Comments:

...the lobby and all other guest amenities such as, exercise/recreational areas, interior pools, business centers, and guest laundry rooms?

Yes ___ No ___ N/A ___ Comments:

...the accessible entrances and all employee only work areas (e.g.: back of registration counter, housekeeping storage rooms, kitchens, administrative offices, etc.)

Yes ___ No ___ N/A ___ Comments:

B. Slopes - Examine each of the interior routes described above:

...excluding accessible ramps, do the corridors have running slopes (i.e.: in the direction of travel) not more than 1:20 (critical dimension of 1 1/4" or less)? [ADA Stds. 4.3.7; 4.8]

Yes ___ No ___ N/A ___ Comments:

...are the interior ramps at least 36" wide between the two handrails to allow for convenient wheelchair travel? [ADA Stds. 4.8.3]

Yes ___ No ___ N/A ___ Comments:

...do the interior ramps have running slopes that are 1:12 or less (critical dimension of 2" or less)? [ADA Stds. 4.8.2]

Yes ___ No ___ N/A ___ Comments:

...do the interior ramps have top, middle and bottom landings that are level and at least 60" long to allow for adequate maneuvering and resting space for persons who use wheelchairs, walkers, and other mobility aids? [ADA Stds. 4.8.4]

Yes ___ No ___ N/A ___ Comments:

...if a ramp is more than 30' long, is there a middle landing that is level, at least as wide as the ramp run it serves, and at least 60" long? [ADA Stds. 4.8.4]

Yes ___ No ___ N/A ___ Comments:

...for corridors into which at least one door swings, is there at least 54" clear floor space opposite the door, to allow a person who uses a wheelchair adequate space to turn and enter the doorway? [ADA Stds. 4.13.6]

Yes ___ No ___ N/A ___ Comments:

C. Doors - Examine each of the interior routes described above:

...with the exception of doors at shallow closets, do the doors to required accessible spaces, and all doors into and within guestrooms allow at least 32" clear passage width for wheelchairs, crutch users, and persons who use walkers? [ADA Stds. 4.1.3(7); 4.13.5; 9.4]

Yes ___ No ___ N/A ___ Comments:

...with the exception of non-accessible guestrooms, does at least one door to each accessible space have door hardware (levers, pulls, panic bars, etc.) that is usable with one hand, without tight grasping, pinching, or twisting of the wrist, since many persons with disabilities may not have high manual dexterity or use of both hands? [ADA Stds. 4.13.9]

Yes ___ No ___ N/A ___ Comments:

...with the exception of guestrooms not designated as accessible, does at least one door to each accessible space have at least 18" of clear floor space on the latch side for persons who use wheelchairs, walkers and other mobility aids to approach and pull open? [ADA Stds. 4.13.6]

Yes ___ No ___ N/A ___ Comments:

D. Protruding Objects - Examine all interior hallways, stairways and other pedestrian routes:

...to minimize the risks to blind persons and persons with low vision, are all of these areas free of objects (i.e.: fire extinguisher, wall mounted lights, electrical meter, sign, pay phone, etc.) mounted between 27" - 80" high, that project into the path more than 4"? [ADA Stds.

4.4]

Yes ___ No ___ N/A ___ Comments:

...are the interior stairs built so blind persons or persons with low vision cannot hit their heads on the underside ([see Fig. 8\(c-1\)](#))? [ADA Stds. 4.4.2]

Yes ___ No ___ N/A ___ Comments:

E. Elevators - If the facility has more than 2 stories, including any basement levels, is there a full size passenger elevator serving each level of the hotel, including the basement for persons with disabilities who cannot use stairs? [ADA Stds. 4.1.3(5)]

Yes ___ No ___ N/A ___ Comments: _____

Examine passenger elevators for the following...

...are all of the elevator lobbies free of ash trays or other elements placed below the elevator call buttons that project more than 4"? [ADA Stds. 4.10.3]

Yes ___ No ___ N/A ___ Comments:

...are all elevator jambs provided with signs placed on both sides designating the floor with 2" minimum height raised letters and Braille characters centered at 60" above the finish floor? [ADA Stds. 4.10.5]

Yes ___ No ___ N/A ___ Comments:

...are all of the elevators equipped with audible tones/bells or verbal annunciators that designate the passage of floors? [ADA Stds. 4.10.13]

Yes ___ No ___ N/A ___ Comments:

...are all of the elevators equipped with audible tones/bells or verbal annunciators that designate the direction of the elevator called - one tone for "up" and two tones for "down"? [ADA Stds. 4.10.4]

Yes ___ No ___ N/A ___ Comments:

...are all the elevators with an emergency communication system equipped with a system that does not require only voice communication (i.e.: either TTY systems or a system of lights and signs designating the meaning of the lights)? [ADA Stds. 4.10.14]

Yes ___ No ___ N/A ___ Comments:



...if the elevators have emergency communication systems behind cabinet doors, is the door pull usable with one hand, without tight grasping, pinching or twisting of the wrist, since many persons with disabilities may not have high manual dexterity or use of both hands? [ADA Stds. 4.10.14]

Yes ___ No ___ N/A ___ Comments:

...are the highest floor control buttons in the elevator(s) mounted within 54" of the floor, with associated raised letters and Braille characters? [ADA Stds. 4.10.12]

Yes ___ No ___ N/A ___ Comments:

F. Stairs - Are there floors connected only by stairs, not an elevator or ramp? [ADA Stds. 4.1.3(4)] If yes, then...

Yes ___ No ___ N/A ___ Comments: _____

...do the stairs have closed risers so a crutch or cane cannot slip through the open space between the stair risers and people will not lose their balance as they climb the stairs? [ADA Stds. 4.9]

Yes ___ No ___ N/A ___ Comments:

...are all stair treads the same depth (at least 11" deep), measured riser to riser, to prevent tripping hazards for persons with disabilities? [ADA Stds. 4.9]

Yes ___ No ___ N/A ___ Comments:

...are there handrails on both sides of the stair at a uniform height of 34"-38" above the front edge of the step? [ADA Stds. 4.9]

Yes ___ No ___ N/A ___ Comments:

...do the handrails extend horizontally at the top and bottom of each stair section to give persons who have difficulty using the stairs a stable gripping location before ascending or descending? [ADA Stds. 4.9]

Yes ___ No ___ N/A ___ Comments:

...are the handrails continuously grippable, without interruption by vertical supports, newel posts, or other construction elements which require repositioning the hands while ascending or descending? [ADA Stds. 4.9]

Yes ___ No ___ N/A ___ Comments:

G. Areas of Rescue Assistance - In hotels that do not have a supervised fire sprinkler system serving every room, are there two 30"x48" wheelchair waiting areas (a.k.a. an "area of rescue assistance" linked to the primary entry by intercom) at each required exit (i.e.: stairs) on levels above or below the ground floor for persons with disabilities who cannot exit the building in case of a fire or emergency? [ADA Stds. 4.1.3(9)]

Yes ___ No ___ N/A ___ Comments: _____

H. Drinking Fountains - Are at least 50% of the drinking fountains on each floor mounted so the spout is no higher than 36"? [ADA Stds. 4.15.3]

Yes ___ No ___ N/A ___ Comments: _____

I. Public Telephones - Are at least the following accessible telephone elements provided per facility... [ADA Stds. 4.1.3(17)]

1. If one public pay phone or one bank of pay phones is provided on a given floor, does at least one pay phone have the following features:

a. Is it mounted with the coin slot no higher than 54" above the floor?

Yes ___ No ___ N/A ___ Comments:

b. Does the accessible phone have volume controls?

Yes ___ No ___ N/A ___ Comments:

c. Do at least 25% (not less than one) of all other pay phones on each floor have volume controls?

Yes ___ No ___ N/A ___ Comments:

d. If the bank of phones includes at least 3 pay phones, is there a shelf and an electrical outlet to allow for TTY (text telephone) use by persons who are deaf?

Yes ___ No ___ N/A ___ Comments:

2. If more than one bank of public pay phones is provided on a given floor, does at least one pay phone per bank have the following features: [ADA Stds. 4.1.3(17)]

a. Is it mounted with the coin slot no higher than 54" above the floor, and one pay phone on that floor with the highest operable element no higher than 48" above the floor?

Yes ___ No ___ N/A ___ Comments:

b. Do the accessible phones have volume controls?

Yes ___ No ___ N/A ___ Comments:

c. Do at least 25% (not less than one) of all other pay phones on each floor have volume controls?

Yes ___ No ___ N/A ___ Comments:

d. If one or more banks of phones includes at least 3 pay phones, is there a shelf and an electrical outlet to allow for TTY (telephone typewriter) use by persons who are deaf?

Yes ___ No ___ N/A ___ Comments:

3. If one house phone or one bank of house phones is provided on a given floor, does at least one house phone have the following features: [ADA Stds. 4.1.3(17)]

a. Is it mounted with the handset cradle no higher than 54" above the floor?

Yes ___ No ___ N/A ___ Comments:

b. Does the accessible phone have volume controls?

Yes ___ No ___ N/A ___ Comments:

c. Do at least 25% (not less than one) of all other house phones on each floor have volume controls?

Yes ___ No ___ N/A ___ Comments: _____

4. Is there a sign at each single pay phone or pay phone bank directing deaf persons to the location of a TTY for use at a pay telephone, if there are 4 or more pay phones on the site? [ADA Stds. 4.30.7; 4.31.9(3)]

Yes ___ No ___ N/A ___ Comments: _____

V. Public/Common Use Restrooms

A. Is each public and employee restroom accessible, with at least one large accessible stall/toilet, one accessible lavatory, and one accessible urinal (if urinals are provided)? [ADA Stds. 4.1.3(11); 4:22]

Yes ___ No ___ N/A ___ Comments: _____

B. Is there adequate room for a person who uses a wheelchair to approach the restroom door from the pull side and pull it open without it hitting the wheelchair - this requires at least 18" of wall space on the latch side of the door? [ADA Stds. 4.13.6]

Yes ___ No ___ N/A ___ Comments: _____

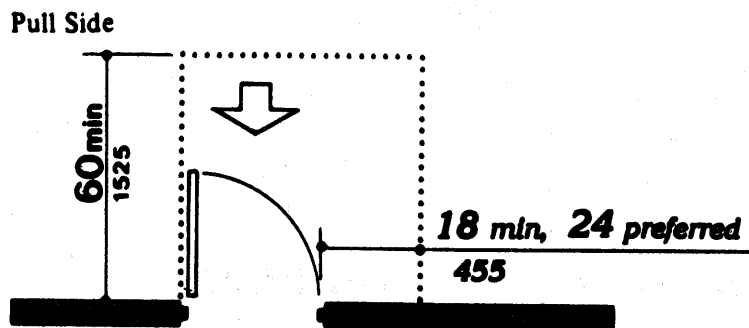

D

ADA Stds. Figure 25(a) - Pull Side, Front Approach

C. When there is a vestibule into the public or employee restroom that does not have fully automatic doors, is there a 30"x48" clear floor space where one can be outside the swing of a hinged door (i.e.: for

out-swinging doors, at least 7'-0" between the exterior door frame and interior door frame) to allow persons who use wheelchairs to proceed through one door without it closing on them and binding the wheelchair as they approach and open the next door? [ADA Stds. 4.13.7]

Yes ___ No ___ N/A ___ Comments: _____

D. Is each accessible toilet centered 18" from the adjacent side wall, which is the distance that will permit a person with a mobility impairment to use the grab bars? [ADA Stds. 4.16.2; 4.17.3]

Yes ___ No ___ N/A ___ Comments: _____

E. Does each accessible toilet have a horizontal grab bar on the adjacent side wall that is at least 40" long and between 33"-36" above the floor for stabilization and assistance during transfer from a wheelchair? [ADA Stds. 4.16.4; 4.17.6]

Yes ___ No ___ N/A ___ Comments: _____

F. Does each accessible toilet have a horizontal grab bar on the wall behind the toilet that is at least 36" long and between 33"-36" above the floor for stabilization and assistance during transfer from a wheelchair? [ADA Stds. 4.16.4; 4.17.6]

Yes ___ No ___ N/A ___ Comments: _____

G. If the accessible toilet is in a stall, does the stall measure at least 60" wide and 56" deep if it is wall mounted or 59" deep if it is floor mounted to allow persons who use wheelchairs to approach the toilet from a variety of transfer positions (i.e.: diagonal or side approaches)? [ADA Stds. 4.17.3]

Yes ___ No ___ N/A ___ Comments: _____

H. If the accessible toilet is in a stall, is the stall door positioned diagonally opposite, not directly in front of, the toilet so persons who use wheelchairs may pull fully into the stall without being blocked by the toilet? [ADA Stds. 4.17.3]

Yes ___ No ___ N/A ___ Comments: _____

I. Is the toilet seat at each accessible toilet between 17"-19" above the floor? [ADA Stds. 4.16.3]

Yes ___ No ___ N/A ___ Comments: _____

J. If there is a lavatory in the accessible stall, is there 42" between the center of the toilet and the near edge of the adjacent lavatory to permit persons with disabilities to transfer onto or off of the toilet? [ADA Stds. 4.17.3]

Yes ___ No ___ N/A ___ Comments: _____

K. If there are more than 5 stalls in any restroom, is there one stall in addition to the large accessible stall, that is 36" wide, has 2 parallel grab bars at 33"-36" off the floor and has an out-swinging door for persons with mobility impairments who can walk? [ADA Stds. 4.22.4]

Yes ___ No ___ N/A ___ Comments: _____

L. Is there at least one lavatory (wash basin) in each public restroom that has each of the following characteristics...

...a 29" high clearance under the front edge and the top of the bowl no higher than 34" above the floor to allow persons who use wheelchairs to pull under the lavatory and use the faucet hardware? [ADA Stds. 4.22.6; 4.19.2]

Yes ___ No ___ N/A ___ Comments:

... drains and hot water pipes that are insulated or otherwise configured to protect against contact? [ADA Stds. 4.19.4]

Yes ___ No ___ N/A ___ Comments:

...a faucet that is easily operable with hardware that is (i.e.: levers, wrist blades, single arm, etc.) usable with one hand, without tight grasping, pinching, or twisting of the wrist, since many persons with disabilities may not have high manual dexterity or use of both hands? [ADA Stds. 4.19.5]

Yes ___ No ___ N/A ___ Comments:

M. Is there an area in each public restroom in which a person who uses a wheelchair can turn around - either a 60" diameter circle or a "T"-shaped turn area as shown in Figure 3 below? [ADA Stds. 4.22.3; 4.2.3]

Yes ___ No ___ N/A ___ Comments: _____

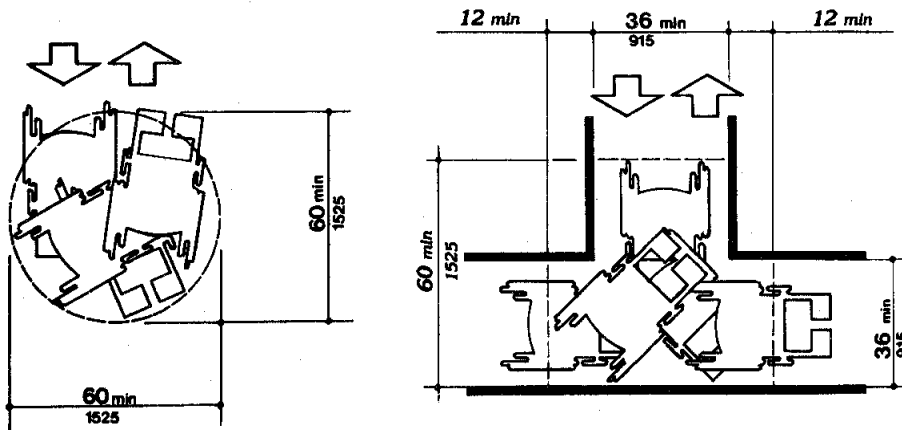

ADA Stds. Figure 3 - Wheelchair Turning Space 60" Diameter Space & "T"-Shaped Space

VI. Interior Signs...

A. If signs are provided for the following spaces, are the signs mounted on the wall (not the door) to the latch side of the door and centered 60" above the floor so that they can be easily located by persons who are blind or have low vision? (Note: signs may be mounted on the door if they are in addition to the wall mounted signs specified here.) [ADA Stds. 4.1.3(16)(a)]

All guestrooms

Yes ___ No ___ N/A ___ Comments: _____

Restaurants, other food service areas, and vending/ice machine areas

Yes ___ No ___ N/A ___ Comments: _____

Ballrooms and meeting rooms

Yes ___ No ___ N/A ___ Comments: _____

Public and employee restrooms

Yes ___ No ___ N/A ___ Comments: _____

Gift shops, newsstands, and other retail shops

Yes ___ No ___ N/A ___ Comments: _____

Other guest amenities, such as exercise/recreational areas, interior pools, business centers, and guest laundry

Yes ___ No ___ N/A ___ Comments: _____

Mechanical and electrical rooms

Yes ___ No ___ N/A ___ Comments: _____

Stairways, fire exits, and areas of rescue assistance

Yes ___ No ___ N/A ___ Comments: _____

B. Do the wall mounted signs provided for the rooms listed above have Braille and raised letters so that they can be read by persons who are blind or have low vision? [ADA Stds. 4.1.3(16)(a); 4.30.4]

Yes ___ No ___ N/A ___ Comments: _____

C. Are all signs at this lodging facility made without reflective materials, such as, brass, chrome, gold, glass or mirror used as text or background, and have letter and numbers that contrast with the background? (Note: reflective signs are permitted if they are in addition to non-reflective signs.) [ADA Stds. 4.1.3(16); 4.30.5]

Yes ___ No ___ N/A ___ Comments: _____

VII. Fire Alarm System...

A. If the building has an audible fire alarm system, do each of the following rooms in the hotel have a visual alarm strobe light mounted on the wall at 80" above the floor to alert deaf persons about emergency situations? [ADA Stds. 4.1.3(14)]

Lobby/front desk

Yes ___ No ___ N/A ___ Comments: _____

Public corridors

Yes ___ No ___ N/A ___ Comments: _____

Restaurants, other food service areas, and vending/ice machine areas

Yes ___ No ___ N/A ___ Comments: _____

Ballrooms and meeting rooms

Yes ___ No ___ N/A ___ Comments:

Public and employee restrooms

Yes ___ No ___ N/A ___ Comments:

Gift shops, newsstands, and other retail shops

Yes ___ No ___ N/A ___ Comments:

Accessible guestrooms/suites and additional guestrooms/suites for use by persons who are deaf or hard of hearing required by Table 9.1.3 below...

(Note: In the guestrooms/suites, this requirement may be satisfied by either a fixed strobe unit hardwired to the building-wide fire alarm system, or by a kit which contains a portable strobe unit that can plug into a 110 volt electrical outlet and is also connected by some means to the building-wide fire alarm system.)

Yes ___ No ___ N/A ___ Comments: _____

(Table 9.1.3)	
Number of Rooms In the Hotel	Rooms for Hearing Impaired Guests
1 - 25	1
26 - 50	2
51 - 75	3
76 - 100	4
101 - 150	5
151 - 200	6
201 - 300	7
301 - 400	8
401 - 500	9
501 - 1000	2% of total rooms
1001 and over	20 plus 1 for each 100 over 1000

Other guest amenities, such as exercise/recreational areas, interior pools, business centers, and guest laundry

Yes ___ No ___ N/A ___ Comments: _____

Other public spaces

Yes ___ No ___ N/A ___ Comments: _____

VIII. Food Service Areas...

A. In each restaurant or other food service establishment on this site, are at least 5% of each type of fixed table or a portion of eating counters (i.e.: where no direct service is provided) accessible, providing a 27" high knee space, at least 19" deep, with table/counter tops at 28"-34" above the floor and split proportionately between smoking and non-smoking areas if provided? [ADA Stds. 5.1]

Yes ___ No ___ N/A ___ Comments: _____

B. Is there a route to these 5% accessible fixed tables that allows at least 36" clear width and has no abrupt vertical level changes greater than 1/4"? [ADA Stds. 5.3;4.3.8]

Yes ___ No ___ N/A ___ Comments: _____

C. At each food service establishment on this site where food and/or drink is served for consumption (i.e.: direct counter service) at counters or bars, is there a minimum 60" long portion providing a 27" high knee space, at least 19" deep, with the counter top at 28"-34" above the floor, or service at accessible tables in the same area? [ADA Stds. 5.2]

Yes ___ No ___ N/A ___ Comments: _____

D. Are the food, drink, condiments and tableware dispensers (juice, coffee, cereal units, condiments, forks, knives, etc.) without:

...operational controls or dispensers higher than 54" (i.e.: out of reach to many persons who use wheelchairs)? [ADA Stds. 5.5]

Yes ___ No ___ N/A ___ Comments:

...operational controls higher than 46" if they are set back 10"-24" from the edge of the counter (i.e.: out of reach to many persons who use wheelchairs)? [ADA Stds. 5.5]

Yes ___ No ___ N/A ___ Comments:

E. If cafeteria style food service lines are provided, are the tray slides no higher than 34" above the floor and queue lines at least 36" wide (42" minimum if u-turns are required) along the approach? [ADA Stds. 5.5]

Yes ___ No ___ N/A ___ Comments: _____

IX. General Guestroom & Suite Issues...

A. Do entry doors, connecting room doors, and interior doors (except doors to shallow closets) into and within all guestrooms and suites allow 32" clear passage width so persons who use wheelchairs, crutches, and other mobility aids can visit or stay in other rooms? [ADA Stds. 9.4]

Yes ___ No ___ N/A ___ Comments: _____

B. Do bathroom doors in all guestrooms allow 32" clear passage width so persons who use wheelchairs, crutches, and other mobility aids can visit or stay in other rooms and use the bathroom? [ADA Stds. 9.4]

Yes ___ No ___ N/A ___ Comments: _____

X. Accessible Guestrooms and Suites...

A. Does the hotel have the proper number of accessible guestrooms and accessible guestrooms with roll-in showers, based on the Table 9.1.2 below? [ADA Stds. 9.1.2]

Yes ___ No ___ N/A ___ Comments: _____

(Table 9.1.2)		
	Column "A"	Column "B"
<u>Total Rooms in Facility</u>	<u>Accessible Rooms</u>	<u>Rooms with Roll-in Showers</u>
1 to 25	1	0
26 to 50	2	0
51 to 75	3	1
76 to 100	4	1
101 to 150	5	2
151 to 200	6	2
201 to 300	7	3
301 to 400	8	4
401 to 500	9	See below*
501 to 1000	2% of total rooms	See below*

1001+	20 + (1 per 100 over 1000)	See below*
Note: The number of accessible guest rooms for a given number of rooms in a hotel (left column) is derived by <u>adding together</u> column "A" and column "B".		
* the number of roll-in shower rooms in hotels with more than 400 guestrooms total equals 4 + (1 per 100 rooms over 400).		

B. Are the proper number of guestrooms for persons who are deaf or hard of hearing provided per Table 9.1.3 below? (Note: In addition to 9.1.2 rooms, the rooms required by Table 9.1.3 must have auxiliary visual alarms, notification devices and telephone accommodations.) [ADA Stds. 9.1.3]

Yes No N/A Comments: _____

C. Are the proper number of the following elements provided for persons who are deaf or hard of hearing in each accessible guestroom/suite, each accessible guestroom/suite required to have a roll-in shower and each additional room for persons who are deaf or hard of hearing required in table 9.1.3: [ADA Stds. 9.3.1]

An electrical outlet within 4' of the telephone jack for TTY use?

Yes No N/A Comments: _____

Visual notification device for door knocks and phone calls (Cannot be same strobe as the fire alarm strobe unit)?

Yes No N/A Comments: _____

Visual smoke alarm device, if audible smoke alarms are provided in the guestrooms?

Yes No N/A Comments: _____

Visual fire alarm (strobe) linked to building-wide fire alarm system, if such system is provided? (Note: In the guestrooms/suites, this requirement may be satisfied by either a fixed strobe unit hardwired to the building-wide fire alarm system, or by a kit which contains a portable strobe unit that can plug into a 110 volt electrical outlet and is also connected by some means to the building-wide fire alarm system.)

Yes No N/A Comments: _____

D. Have the required accessible guestrooms been distributed among the various types of rooms, such as those listed below, to provide persons with disabilities the same or similar choice as other persons... [ADA Stds. 9.1.4]

Rooms with One Bed?

Yes ___ No ___ N/A ___ Comments: _____

Rooms with Two Beds?

Yes ___ No ___ N/A ___ Comments: _____

Connecting Rooms?

Yes ___ No ___ N/A ___ Comments: _____

Whirlpool Tub Suites?

Yes ___ No ___ N/A ___ Comments: _____

Other types of Suites and Guestrooms?

Yes ___ No ___ N/A ___ Comments: _____

E. Are smoking and non-smoking accessible guestrooms provided based upon the ratio of smoking and non-smoking guestrooms in the facility so persons with disabilities have the same options as everyone else? [ADA Stds. 9.1.4]

Yes ___ No ___ N/A ___ Comments: _____

F. Do all entry doors to accessible guestrooms and other interior doors (except doors on shallow closets) allow at least 32" of clear passage width to accommodate persons who use wheelchairs, crutches, and walkers? [ADA Stds. 9.2.2(3); 4.13.5]

Yes ___ No ___ N/A ___ Comments: _____

G. Is the door hardware (levers, pulls, panic bars, etc.) on all entry doors to accessible guestrooms and other passage doors within the room usable with one hand, without tight grasping, pinching, or twisting of the wrist, since many persons with disabilities may not have high manual dexterity or use of both hands? [ADA Stds. 9.2.2(3); 4.13.9]

Yes ___ No ___ N/A ___ Comments: _____

H. On the pull side of each door (i.e.: entry door, connecting room door, bathroom doors and other passage doors) in every accessible guestroom/suite, are there at least 18" of clear floor space on the latch side for persons who use wheelchairs, walkers, and other mobility aids to approach and pull open? [ADA Stds. 9.2.2(3); 4.13.6]

Yes ___ No ___ N/A ___ Comments: _____

I. Is the security latch or bolt on the hall door mounted no higher than 48" above the floor so it is within the reach of persons who use wheelchairs and is it operable with one hand, without tight grasping, pinching or twisting of the wrist? [ADA Stds. 9.2.2(3); 4.13.9]

Yes ___ No ___ N/A ___ Comments: _____

J. Regarding maneuvering space around the bed(s) in the accessible guestrooms...

...in accessible guestrooms with one bed, is there at least a 36" wide route on each side of the bed to allow persons who use wheelchairs to transfer onto the bed from either side? [ADA Stds. 9.2.2(1)]

Yes ___ No ___ N/A ___ Comments:

...in accessible guestrooms with two beds next to one another, is there a minimum of 36" between the two beds to allow persons who use wheelchairs to transfer onto either bed? [ADA Stds. 9.2.2(1)]

Yes ___ No ___ N/A ___ Comments:

... is there clear passage at the foot of each bed that is at least 36" wide so that persons who use wheelchairs can approach and use the accessible features throughout the room? [ADA Stds. 9.2.2(2)]

Yes ___ No ___ N/A ___ Comments:

K. Are the drapery wands and controls on fixed lamps and HVAC units easily operable with one hand, without tight grasping, pinching or twisting of the wrist, since many persons with disabilities may not have high manual dexterity or use of both hands? [ADA Stds. 9.2.2(5); 4.27.4]

Yes ___ No ___ N/A ___ Comments: _____

L. Are all drapery control wands, fixed lamps and HVAC controls in accessible guestrooms placed within 54" of the floor for side approach or 48" of the floor for forward approach so persons who use wheelchairs can approach and use the controls? [ADA Stds. 9.2.2(5); 4.27.3]

Yes ___ No ___ N/A ___ Comments: _____

M. Are the rod and shelf in the clothes closet or wall mounted unit within 54" of the floor for side approach or 48" of the floor for forward approach so persons who use wheelchairs can approach and use the rod and shelf? [ADA Stds. 9.2.2(4); 4.25.3]

Yes ___ No ___ N/A ___ Comments: _____

N. Accessible Guestroom Bathroom Issues:

1. Do bathroom doors in accessible guestrooms allow at least 32" of clear passage width to accommodate persons who use wheelchairs, walkers and other mobility aids? [ADA Stds. 9.2.2(3); 4.13.5]

Yes ___ No ___ N/A ___ Comments:

2. Is the bathroom door hardware (levers, pulls, etc.) easily operable with one hand, without tight grasping, pinching or twisting of the wrist, since many persons with disabilities may not have high manual dexterity or use of both hands? [ADA Stds. 9.2.2(3); 4.13.9]

Yes ___ No ___ N/A ___ Comments:

3. Is the accessible toilet in each accessible guestroom bathroom centered 18" from the adjacent side wall, which is the distance that will permit a person with a mobility impairment to use the grab bars? [ADA Stds. 9.2.2(6)(e); 4.23.4; 4.16.2]

Yes ___ No ___ N/A ___ Comments:

4. Does the toilet in each accessible guestroom bathroom have a horizontal grab bar along the adjacent side wall that is at least 42" long and mounted 33"-36" above the floor for stabilization and assistance during transfer from a wheelchair? [ADA Stds. 9.2.2(6)(e); 4.23.4; 4.16.2]

Yes ___ No ___ N/A ___ Comments:

5. Does the accessible toilet in each accessible guestroom bathroom have a horizontal grab bar along the wall behind the toilet that is at least 36" long and mounted 33"-36" above the floor for stabilization and assistance during transfer from a wheelchair? [ADA Stds. 9.2.2(6)(e); 4.23.4; 4.16.2]

Yes ___ No ___ N/A ___ Comments:

6. Is the toilet seat in each accessible toilet room between 17"-19" above the floor? [ADA Stds. 4.16.3]

Yes ___ No ___ N/A ___ Comments:

7. Is the lavatory (wash basin) in each accessible guestroom bathroom no more than 34" high with at least 29" high clearance under the front edge to allow persons who use wheelchairs to pull under the lavatory and use the faucet hardware? [ADA Stds. 9.2.2(6)(e); 4.23.6; 4.19.2]

Yes ___ No ___ N/A ___ Comments:

8. Does the lavatory in each accessible guestroom bathroom have drain and hot water pipes that are insulated or otherwise configured to protect against contact? [ADA Stds. 9.2.2(6)(e); 4.23.6; 4.19.4]

Yes ___ No ___ N/A ___ Comments:

9. Does the lavatory in each accessible guestroom bathroom have a faucet that is easily operable (i.e.: levers, wrist blades, single arm, etc.) and usable with one hand, without tight grasping, pinching, or twisting of the wrist? [ADA Stds. 9.2.2(6)(e); 4.23.6; 4.19.5]

Yes ___ No ___ N/A ___ Comments:

10. Is there clear floor space in each accessible guestroom bathroom where persons who use wheelchairs can turn around - either a 60" diameter circle or a "T"-turn area as shown in Figure 3 on page 15? [ADA Stds. 9.2.2(6)(e)]

Yes ___ No ___ N/A ___ Comments:

11. Is there adequate room for a person who uses a wheelchair to approach the bathroom door in each accessible guestroom bathroom from the pull side and pull it open without it hitting the wheelchair? (Note: this requires at least 18" of wall space on the latch side of the door.) [ADA Stds. 9.2.2(3); 4.13.6]

Yes ___ No ___ N/A ___ Comments:

12. Are there towel racks or bars placed within 54" of the floor for side approach or 48" of the floor for forward approach so persons who use wheelchairs can approach and use the towel racks? [ADA Stds. 9.2.2(4); 4.2.6]

Yes ___ No ___ N/A ___ Comments:

13. Are all of the bathroom floors in the accessible guestrooms slip-resistant so persons who use crutches and walkers do not fall? [ADA Stds. 4.5]

Yes ___ No ___ N/A ___ Comments:

O. Bathtubs - Do bathtubs (if provided) in the designated accessible guestrooms, comply with the

following:

1. Are the tub faucet controls positioned between the center of the end wall and the open side of the tub so persons with disabilities may approach and adjust the controls before they transfer onto the tub seat to bathe? [ADA Stds. 4.23.8;4.20.2]

Yes ___ No ___ N/A ___ Comments:

2. Can the faucet controls and shower diverter be turned on and off easily and are they operable and usable with one hand, without tight grasping, pinching or twisting of the wrist (i.e.: levers, single arm, etc.)? [ADA Stds. 4.23.8; 4.20.5]

Yes ___ No ___ N/A ___ Comments:

3. Is there a transfer tub seat (that can be securely attached to the tub) available for persons who may not be able to stand in the tub to bathe? [ADA Stds. 4.23.8; 4.20.3]

Yes ___ No ___ N/A ___ Comments:

4. Is there an adjustable height hand-held shower wand with at least a 60" long hose provided so persons who bathe from a seated position may wash and rinse with the directional spray? [ADA Stds. 4.23.8; 4.20.6]

Yes ___ No ___ N/A ___ Comments:

5. Is there a horizontal grab bar at the foot of the tub (by the controls) that is at least 24" long for stabilization while a person with a disability adjusts the water controls - see Figure 34 on page 25? [ADA Stds. 4.23.8; 4.20.4]

Yes ___ No ___ N/A ___ Comments:

6. Is there a horizontal grab bar at the head of the tub that is at least 12" long for stabilization and aid in transfer from a wheelchair to the fixed tub seat - see Figure 34 on page 25? (Note: in tubs with built-in seats at the head of the tub, this grab bar is not required.) [ADA Stds. 4.23.8; 4.20.4]

Yes ___ No ___ N/A ___ Comments:

7. Are there two horizontal grab bars (one high/one low) along the side of the tub that are at least 24" long for stabilization and aid in transfer from a wheelchair to the fixed tub seat - see Figure 34 below? [ADA Stds. 4.23.8; 4.20.4]

Yes ___ No ___ N/A ___ Comments:

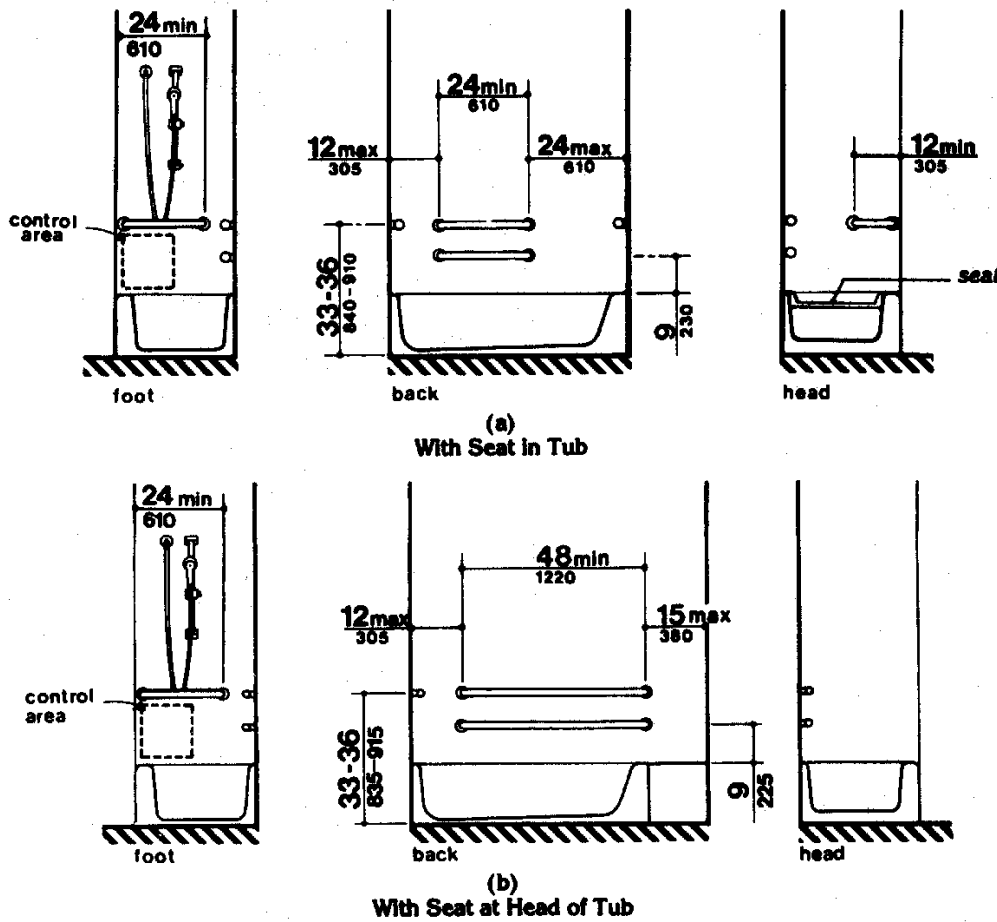

[D](#)

ADA Stds. Figure 34 - Grab Bars at Bathtubs

8. Is the gap between the wall and the inside face of each grab bar exactly 1 1/2" to accommodate persons with disabilities who rest their forearms on the bars for stabilization so the arm cannot accidentally pass between the grab bar and wall especially if a fall occurs? [ADA Stds. 4.23.8; 4.20.4]

Yes ___ No ___ N/A ___ Comments:

P. Roll-in Showers -

1. If there are more than 50 guestrooms/suites in the facility, are the proper number of accessible rooms with roll-in showers provided per table 9.1.2 below. (Note: accessible rooms with roll-in showers must be provided in addition to standard accessible guestrooms/suites.) [ADA Stds. 9.1.2]

Yes ___ No ___ N/A ___ Comments:

(Table 9.1.2)		
	Column "A"	Column "B"
<u>Total Rooms in Facility</u>	<u>Accessible Rooms</u>	<u>Rooms with Roll-in Showers</u>
1 to 25	1	0
26 to 50	2	0
51 to 75	3	1
76 to 100	4	1
101 to 150	5	2
151 to 200	6	2
201 to 300	7	3
301 to 400	8	4
401 to 500	9	See below*
501 to 1000	2% of total rooms	See below*
1001+	20 + (1 per 100 over 1000)	See below*
Note: The number of accessible guest rooms for a given number of rooms in a hotel (left column) is derived by <u>adding together</u> column "A" and column "B".		
* the number of roll-in shower rooms in hotels with more than 400 guestrooms total equals 4 + (1 per 100 rooms over 400).		

2. If there are more than 50 guestrooms/suites, are all required roll-in showers at least 30" wide by 60" long or 36" wide by 60", as configured in Figure 57 below, so persons who use wheelchairs may transfer to the attached seat or use a shower wheelchair while showering? [ADA Stds. 9.1.2; Fig. 57]

Yes ___ No ___ N/A ___ Comments:

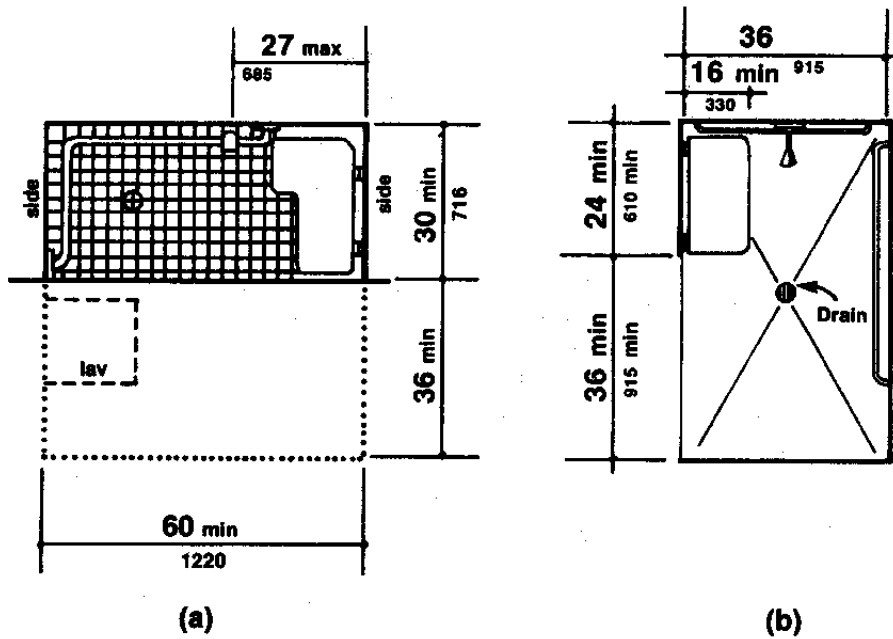

[D](#)

ADA Stds. Figure 57 - Roll-in Shower with Folding Seat

3. Do the roll-in showers have a securely fastened folding seat at 17"-19" above the floor onto which persons who use wheelchairs may transfer to shower? [ADA Stds. 4.21.3]

Yes ___ No ___ N/A ___ Comments:

4. Are the faucet controls and shower wand positioned on the wall along the side of the shower seat so they are operable from the folding shower seat or from the shower wheelchair? [ADA Stds. 4.21.5]

Yes ___ No ___ N/A ___ Comments:

5. Is there a horizontal grab bar on the wall alongside the shower seat (but not behind the shower seat) for stabilization and aid in transfer from a wheelchair to the folding shower seat? [ADA Stds. 4.21.2; Fig. 57]

Yes ___ No ___ N/A ___ Comments:

6. Is there a horizontal grab bar on the wall opposite the seat for stabilization and aid in maneuvering while in a shower wheelchair? [ADA Stds. 4.21.2]

Yes ___ No ___ N/A ___ Comments:

7. Are the roll-in showers free of doors that would impede wheelchair transfer onto the seat?

[ADA Stds. 4.21.8]

Yes ___ No ___ N/A ___ Comments:

8. Are the roll-in showers free of curbs or lips at the shower floor that would impede wheelchair approach and transfer onto the folding shower seat? [ADA Stds. 4.21.7]

Yes ___ No ___ N/A ___ Comments:

9. Do roll-in showers have faucet controls that are easily operable with one hand (i.e.: levers, wrist blades, single arm, etc.) without tight grasping, pinching or twisting of the wrist? [ADA Stds. 4.21.5]

Yes ___ No ___ N/A ___ Comments:

10. Is there an adjustable height shower wand with at least a 60" long hose provided for persons who must shower from a seated position? [ADA Stds. 4.21.6]

Yes ___ No ___ N/A ___ Comments:

11. Is the gap between the wall and the inside face of each grab bar exactly 1 1/2" to accommodate persons with disabilities who rest their forearms on the bars for stabilization so the arm cannot accidentally pass between the grab bar and wall especially if a fall occurs? [ADA Stds. 4.21.4]

Yes ___ No ___ N/A ___ Comments:

Q. Other Showers in Accessible Guestrooms/Suites - Accessible guestrooms/suites that are not required to have roll-in showers may have an accessible bathtub, a small shower as shown in Figure 35(a) below, or a large shower as shown in Figure 35(b) page 30.

1. Small Showers -

a. Do all small showers, if provided in accessible guestroom/suites, measure exactly 36" wide by 36" deep as shown in Figure 35(a) below: [ADA Stds. 4.21.2]

Yes ___ No ___ N/A ___ Comments:

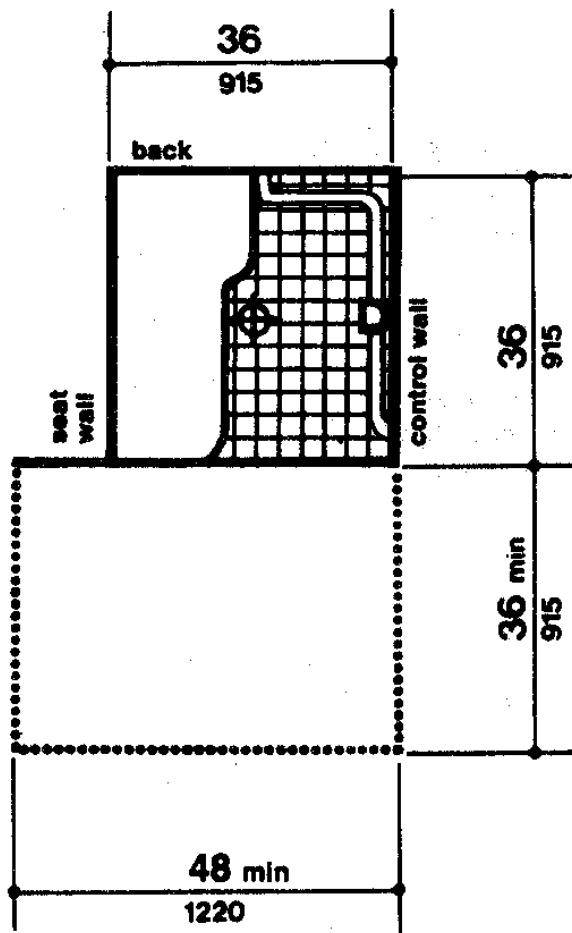

D

ADA Stds. Figure 35(a) - Small Shower Size and Clearances

b. Do they have a fixed or folding seat between 17"-19" above the floor, onto which a person who uses a wheelchair may transfer to shower? [ADA Standards 4.21.3]

Yes ___ No ___ N/A ___ Comments: _____

c. Is there a 36" wide by 48" long clear floor space directly outside the shower for persons who use wheelchairs to approach and use the shower as shown in Figure 35(a) above? [ADA Standards 4.21.2]

Yes ___ No ___ N/A ___ Comments: _____

d. Does the 36" x 48" clear floor space directly outside the shower extend at least 12" past the seat wall of the shower to allow for a seat-to-seat transfer from the wheelchair? [ADA Standards 4.21.2]

Yes ___ No ___ N/A ___ Comments: _____

e. Do all small showers have faucet controls that are easily operable with one hand (i.e.: levers, wrist blades, single arm, etc.) without tight grasping, pinching or twisting of the wrist? [ADA Stds. 4.21.5]

Yes ___ No ___ N/A ___ Comments: _____

f. Is there a horizontal grab bar on the wall alongside the shower seat (but not behind the shower seat) for stabilization and to aid in transfer from a wheelchair to the folding shower seat as shown in Figure 37(a) below? [ADA Stds. 4.21.4; Fig. 37]

Yes ___ No ___ N/A ___ Comments: _____

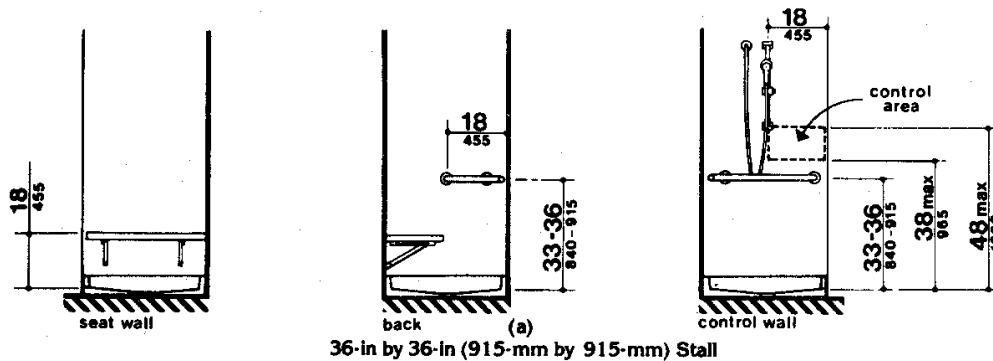

ADA Stds. Figure 37(a) - Grab bars at Small Shower Stalls

D

g. Is there a horizontal grab bar on the wall opposite the seat as shown in Figure 37(a) above? [ADA Stds. 4.21.4; Fig. 37]

Yes ___ No ___ N/A ___ Comments: _____

h. Are the accessible small showers free of doors that would impede wheelchair transfer to the seat? [ADA Stds. 4.21.8]

Yes ___ No ___ N/A ___ Comments: _____

i. Are all of the small showers free of curbs or lips greater than 1/2" high at the shower floor that would impede wheelchair approach and transfer onto the folding shower seat? [ADA Stds. 4.21.7]

Yes ___ No ___ N/A ___ Comments: _____

j. Is there an adjustable height shower wand with at least a 60" long hose provided for persons who must shower from a seated position? [ADA Stds. 4.21.6]

Yes ___ No ___ N/A ___ Comments: _____

k. Is the gap between the wall and the inside face of each grab bar exactly 1 1/2" to accommodate persons with disabilities who rest their forearms on the bars for stabilization so the arm cannot accidentally pass between the grab bar and wall especially if a fall occurs? [ADA Stds. 4.21.4]

Yes ___ No ___ N/A ___ Comments:

2. Large Showers - Do large showers in accessible guestrooms/suites, if provided, have the following features...

a. Do large showers measure at least 30" wide by 60" deep as shown in Figure 35(b) below? [ADA Stds. 4.21.2]

Yes ___ No ___ N/A ___ Comments:

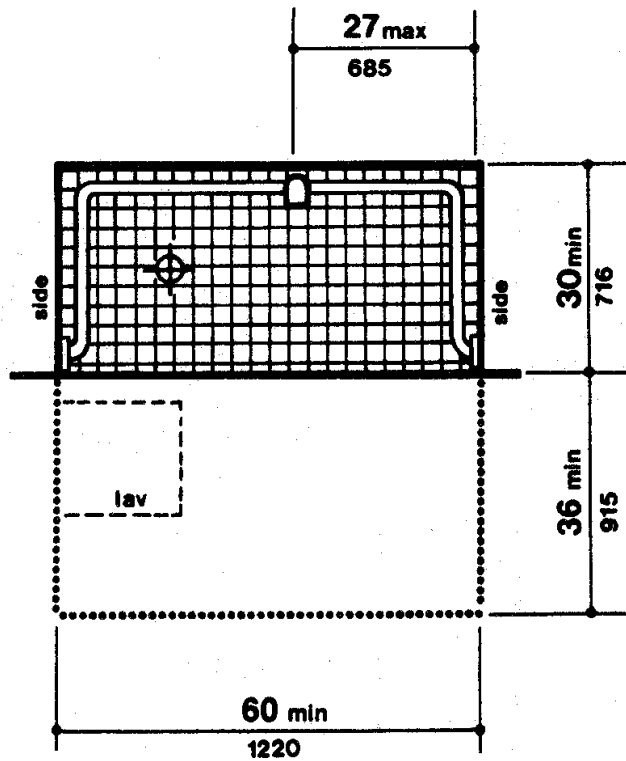

ADA Stds. Figure 35(b) - Large Shower Size and Clearances

b. Are all large showers free of curbs or lips at the shower floor that would impede wheelchair approach and transfer onto the folding shower seat? [ADA Stds. 4.21.7]

Yes ___ No ___ N/A ___ Comments:

c. Do all large showers have faucet controls that are easily operable with one hand without tight grasping, pinching, or twisting of the wrist (i.e.: levers, wrist blades, single arm, etc.)? [ADA Stds. 4.21.5]

Yes ___ No ___ N/A ___ Comments:

d. Is there an adjustable height shower wand with at least a 60" long hose provided for persons who must shower from a seated position? [ADA Stds. 4.21.6]

Yes ___ No ___ N/A ___ Comments:

e. Is there a horizontal grab bar along each of the three shower walls at 33"-36" above the floor as shown in Figure 37(b) below? [ADA Stds. 4.21.2; Fig. 37(b)]

Yes ___ No ___ N/A ___ Comments:

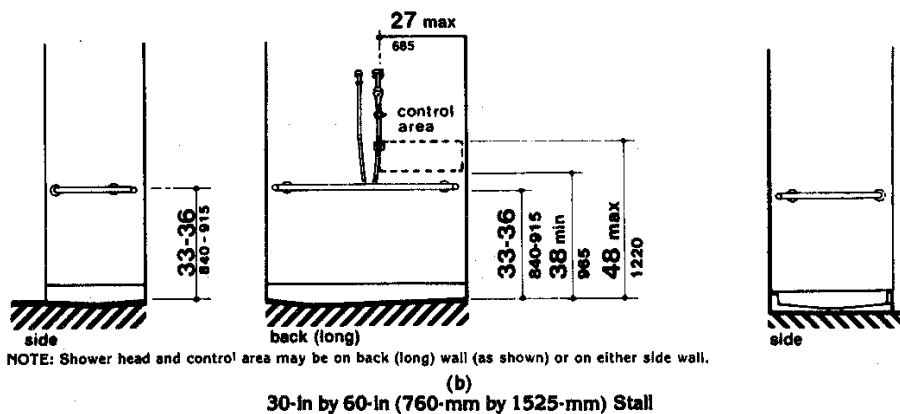

[D](#)

ADA Stds. Figure 37(b) - Grab bars at Large Shower Stalls

f. Is the gap between the wall and the inside face of each grab bar exactly 1 1/2"? [ADA Stds. 4.21.4]

Yes ___ No ___ N/A ___ Comments:

g. Are the accessible large showers free of doors? [ADA Stds. 4.21.8]

Yes ___ No ___ N/A ___ Comments:

XI. Operating Issues...

1. Can persons with disabilities reserve accessible guestrooms/suites in the same ways and on the same terms that other persons can reserve guestrooms/suites? [28 CFR 36.302]

Yes ___ No ___ N/A ___ Comments: _____

2. Do all reservations staff (including staff located on-site at the lodging facility and staff located off-site at a reservations center) have ready access to information about the lodging facility's accessible guestrooms/suites (including specific information on types and sizes of accessible showers, bathtubs and other features such as, tub seats) for use in making reservations and answering questions? [28 CFR 36.302]

Yes ___ No ___ N/A ___ Comments: _____

3. Are accessible guestrooms/suites held for possible use by persons with disabilities until all other rooms in the same price category have been rented? [28 CFR 36.302]

Yes ___ No ___ N/A ___ Comments: _____

4. Are rates for accessible guestrooms/suites the same as rates for guestrooms/suites that are not designated accessible? [28 CFR 36.301(c)]

Yes ___ No ___ N/A ___ Comments:

5. Are accessible features inside and outside the lodging facility maintained in good working order? (For example, repairing cracks in sidewalks on exterior routes; placing portable display racks and potted plants so they do not impede exterior and interior routes; snow removal on exterior routes; replacing damaged or stolen room identification signs; tightening or adjusting accessible toilet seat fasteners, grab bars, handrails and door hardware; battery replacement for TTYs, portable visual smoke alarms and door-knock notification devices; trimming tree branches and shrubs that pose safety hazards for blind persons and persons with low vision) [28 CFR 36.211]

Yes ___ No ___ N/A ___ Comments: _____

6. Are fire-safety information, maximum room rate information, telephone and television information cards, guest services guides, restaurant menus, room service menus, and all other printed materials provided for use by guests also available in alternate formats so that blind persons and persons with low vision can read them? (Alternate formats include Braille, large print, and audio recordings) [28 CFR 36.303(b); 36.303(b)]

Yes ___ No ___ N/A ___ Comments:

7. Are accessible guestrooms arranged so that persons who use wheelchairs, crutches and other mobility aids can approach and use beds; bathrooms; closets; heating, air conditioning and drapery controls; lamps and light switches; telephones; computer outlets; mirrors; televisions; balconies; and other room features without moving furniture? (Note: wheelchairs need 36" of clear passage width) [28 CFR 36.304(b)(4)]

Yes ___ No ___ N/A ___ Comments: _____

8. Does the lodging facility allow persons with disabilities to use service animals, without imposing any extra charges or conditions, in guestroom/suites and all public areas of the facility (e.g.: restaurants, bar

areas, facility grounds, vans/shuttle buses, and other areas for meeting or recreation)? [28 CFR 36.302(c)]

Yes ___ No ___ N/A ___ Comments: _____

9. Does the facility have a reasonable number of TTYs available for use by persons who are deaf or hard of hearing? [28 CFR 36.303(d)]

Yes ___ No ___ N/A ___ Comments: _____

10. Is there a TTY available at the front desk so that lodging facility personnel can communicate with persons who are deaf or have speech impairments (e.g.: taking room service orders, answering requests for assistance, etc.)? [28 CFR 36.303]

Yes ___ No ___ N/A ___ Comments: _____

11. If the lodging facility has televisions in guestrooms/suites, is a close-captioning decoder provided for use by persons who are deaf or hard of hearing or do televisions include built-in captioning features? [28 CFR 36.303(e)]

Yes ___ No ___ N/A ___ Comments: _____

12. Are hotel staff available to move furniture, and provide and adjust accessible features in guestrooms when features require installation or adjustment to ensure accessibility (e.g.: installing bathtub seats, lowering adjustable shower wands, placing folding seats in transfer showers in the down position, installing auxiliary fire alarm strobes into the building alarm system, activating the television's closed captioning system)? [28 CFR 36.302(a)]

Yes ___ No ___ N/A ___ Comments: _____

13. Is the hotel staff trained to offer assistance, upon request, to persons with disabilities who cannot transport their luggage to/from their guestrooms/suites and who may need assistance in locating guestrooms and hotel amenities? [28 CFR 36.302(a)]

Yes ___ No ___ N/A ___ Comments: _____

14. If the facility offers transportation services for guests, is accessible transportation readily available for guests who use wheelchairs and other mobility aids without additional charge? [28 CFR 36.310]

Yes ___ No ___ N/A ___ Comments: _____

15. If a portion of the lobby is used for breakfast service, is it approachable and usable by persons with disabilities who cannot climb steps or stairs? [ADA Stds. 4.3.8]

Yes ___ No ___ N/A ___ Comments: _____

Reproduction of this document is encouraged.

END OF CHECKLIST

[Back to Top of Page](#)

- October 2, 2001